

**sinclair**

**ZX80**

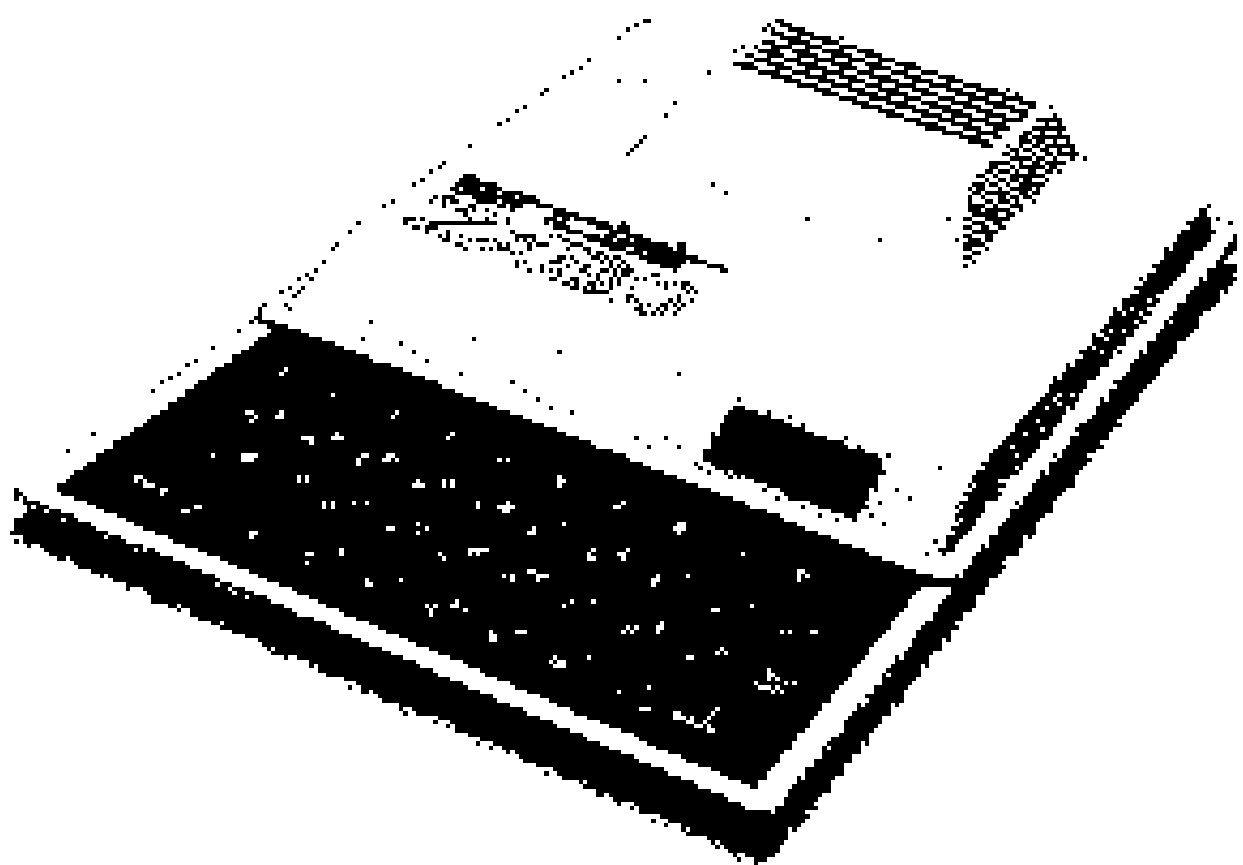

assembly instructions

# ***PLEASE READ THROUGH INSTRUCTIONS BEFORE STARTING ASSEMBLY.***

## **1. PREPARATION**

First select a suitable workspace which should be clean, dry, with adequate lighting and preferably free from distractions. You will need the following tools:

1. A light electric soldering iron, say 15 - 25 watts, with a fine bit.
2. Fine solder with a resin flux core: NOT acid type flux.
3. A sharp pair of sidecutters.
4. A magnifying glass -- optional, but very useful for inspecting solder joints and looking for shorts etc. on the printed circuit board.
5. Either a reel of desoldering braid or a "solder sucker" type tool -- it is almost impossible to remove a component with more than two leads from a board with plated through holes.
6. A piece of foam of at least the same area as the circuit board is useful for holding components in place whilst they are being soldered. The alternative is to bend the component leads flat against the back of the board, being careful not to short to adjacent tracks, but again, this can make it difficult to correct any mistakes once soldered.

## **2. PRECAUTIONS**

Four of the integrated circuits (IC's) in the kit are of M.O.S. construction and are therefore susceptible to damage from static.

These IC's are the C.P.U. (IC1) and the memories (IC2, 3 and 4). Modern M.O.S. devices are not as fragile as they once were, but since these four are the most expensive IC's in the machine, a few handling precautions are worthwhile:-

1. Keep all the IC's in their protective packing until you actually want to install them in their sockets.
2. Never plug in or unplug the IC's with power applied to the board.
3. Use a soldering iron with a properly earthed bit if you need to solder to the board once the IC's are fitted.
4. Earth yourself, e.g. by touching an earthed piece of metal, prior to handling the IC's. If you get a shock doing this, a change of clothing may be advisable -- cotton and wool are less static prone than man-made fibres.
5. The white graphical 'component location' markings on the PCB for the following capacitors C3, C9, C11, C14, C15 differ slightly to the location markings for other capacitors.

To ensure the correct locations of these capacitors during assembly extra care should be taken. Study diagrams A and B on the reverse side of this sheet.

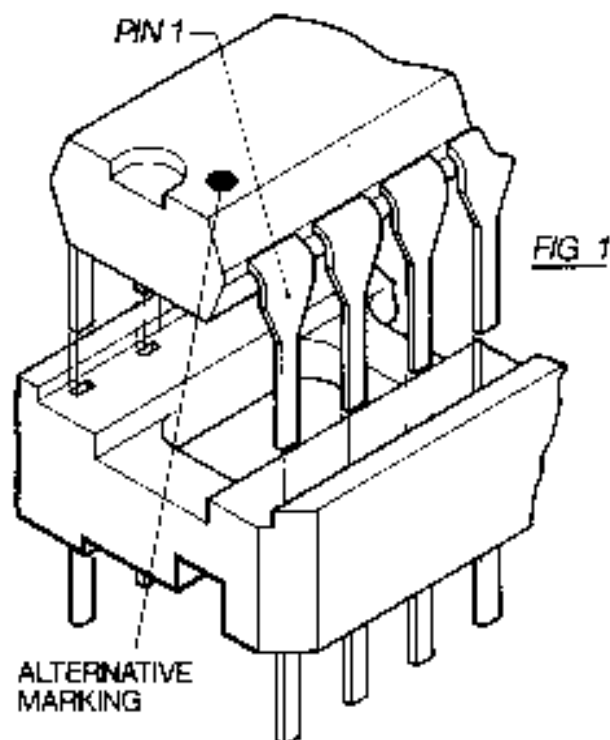

### 3. ASSEMBLY

First identify and check all the components. Note that some components need to be mounted one particular way round, as marked on the board — all the IC's, all the diodes (prefix D) and the two electrolytic capacitors (C8 and C10). All the resistors, the rest of the capacitors and the ceramic filter may be put either way round.

The IC's are identified by a notch at one end (fig. 1) and it is worth noting that the IC sockets also have identification of pin 1 position (fig. 1) — they can be put in either way round, but it will avoid possible confusion later on if they are mounted the same way round as the IC's they will carry. Note that all the IC's face the same way on the board, i.e. notch facing away from the keyboard.

**N.B. SOME IC'S MAY ONLY HAVE A MARK ABOVE PIN 1.**

The diodes have their + end identified by a band painted on the body — or in the case of components with multiple bands, the widest band (fig. 2).

The electrolytic capacitors (C8, 10) will have either their + or - wires marked on the can (fig. 3). In addition, the + lead will usually be longer than the - .

FIG 2

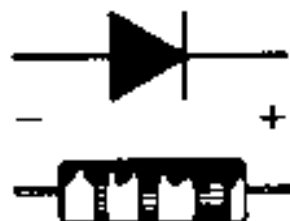

DIODE

FIG 3



ELECTROLYTIC CAPACITOR

The power and tape sockets, the modulator and the regulator (IC22) also need to be mounted the right way round, but provided the drawings are followed (figs 4 & 5) this will happen automatically.

The board will be supplied with the keyboard fitted. All components go on this side, which has the component numbers printed on it as a guide to assembly — the component list tells you which component goes where.

All soldering should be done on the opposite side of the board (the side with a green coating — this stops solder going where it's not needed). Note that not all the holes have components in them — only the component holes need soldering, and only on the "green" side. Top soldering isn't necessary since the board has plated through holes. Do solder all component leads, though, even if they don't seem to go anywhere — they will be connected on the other side. Be careful not to put solder on the edge connector, and keep the iron away from the keyboard — it is plastic, and easily melted.

#### 4. SUGGESTED CONSTRUCTION ORDER

1. The IC sockets — but not the IC's yet. Make sure that each IC position has a socket with the appropriate number of pins — the component list says how many each IC has. IC22 doesn't have a socket — see step 5.
2. The resistors, diodes (D1 and D2 not used) and capacitors. Note that C8 mounts vertically on the board, while C10 lays down — make sure the leads are long enough to allow this. The top won't fit if C10 isn't flat enough.

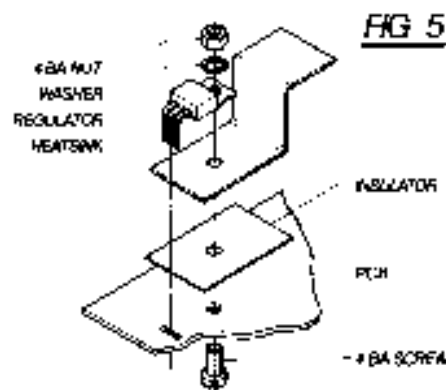
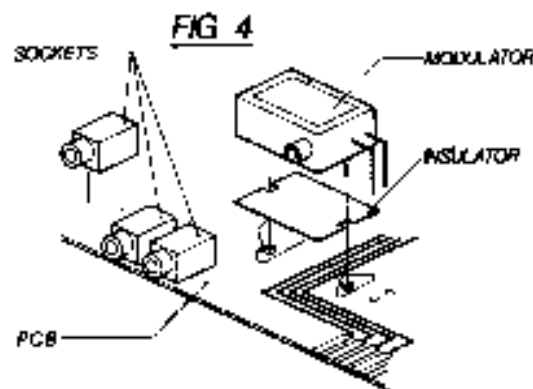

3. The tape and power sockets (fig. 4). Push the sockets right down before soldering, or again the top won't go on.
4. The ceramic filter X1.
5. The regulator IC22 (fig. 5). Bend the regulator's leads as in the diagram — not too close to the plastic — and bolt it down firmly with the heatsink **before** soldering. Don't forget the insulator.
6. The modulator (fig. 4). Again, bend the modulator's leads to fit through the holes indicated on the board. A larger bit, or even a more powerful iron, may prove useful when soldering the modulator's pins. Don't try to bend these pins over — the board may get damaged. As before, make quite sure the insulator is in position before soldering.
7. Finally, insert all the IC's into their sockets, saving IC's 1 to 4 until last. The IC pins will be splayed out slightly and may need to be bent inwards before they will fit. This can be done by pushing each row of pins gently against a flat surface.

#### 5. TESTING

The board is now assembled — but before trying the computer out, check it over very carefully for any stray solder blobs, and make sure that all the components are in the correct place: in particular, that the IC's and diodes are in the right way round. Any IC's which are inserted incorrectly may not only be destroyed themselves, but could also cause damage to others (see service).

Don't mount the board permanently in the case to begin with — simply rest it in the lower moulding whilst testing (see "Getting Started" — chapter 2 in "A Course in Basic Programming").

The regulator heatsink will get hot after the machine has been on for a time, and the large IC's will also get warm.

#### 6. POWER SUPPLY

You may wish to use your own power supply to operate the ZX80. DC only should be used, with positive connected to the tip of a 3.5mm jack plug. Make absolutely certain that the supply is of correct polarity and voltage before switching on (see service). The

voltage should be between 7 and 12 volts, and need not be regulated: if there is too much ripple, however, it will cause horizontal lines to pass through the picture. The computer will take a current of between 350 and 500 mA (typically 400mA) which remains essentially constant.

## 7. FAULTS

If the computer doesn't work properly, all that can be done without special equipment is to recheck the soldering and component locations (which you should have done before switching on!). Occasionally the likely area to look in can be narrowed down a little.

If the computer doesn't work at all, leave it on for a few minutes and feel the regulator (IC22). If it is not getting warm, check the mains supply, the fuse, and that the supply plug is in the right socket. If the regulator is getting warm, check the connection to the TV, and make sure the set is tuned in properly, (to UHF channel 36 — try between 33 and 39).

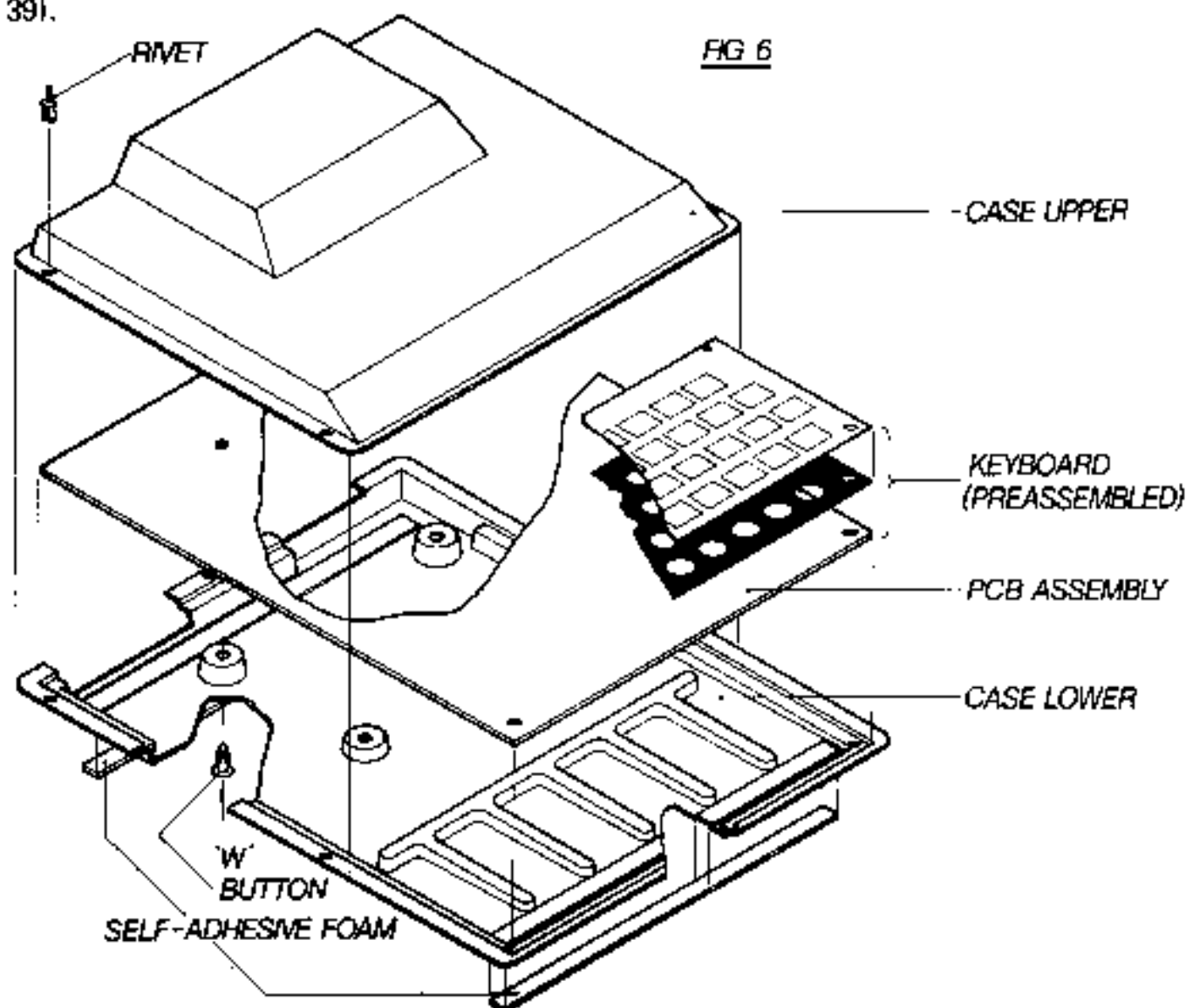

If the computer works for a while and then goes off, and the regulator gets very hot, make sure it is bolted firmly down on the heatsink. If the cursor appears on the screen (a black square with a white K in it) but the keyboard won't enter, first check that diodes D3 — D10 are the right way round, and that IC10 is properly in position.

If the screen goes clear but there isn't a cursor, first try switching off then on again after a few seconds. If that makes no difference, check that C10 and R21 are properly soldered in.

Finally, if there is still no cursor, remove all I.C.'s from their sockets and with an Ohm meter check for a "short" due to a solder bridge between all the I.C. socket pins and the tracks running between them.

Once everything checks out, the case may be assembled (fig. 6). Fix the rivets in their holes by pushing the rod down until it is flush with the head.

## 8. OPTIONS

As constructed, the computer will display black symbols on a white background on your TV screen: this has been found to give the best readability. However, you may wish to use the more common white letters on black if your TV set can give a good enough picture, and a simple modification can accomplish this. First, cut the track between points "A" and "C" on the underside of the board with a sharp knife -- be careful not to slip! and solder in a short wire link (e.g. a resistor lead off-cut) between points "A" and "B".

Remember that the graphics symbols will also be reversed, and that reverse letting will now give black letters in a white box.

## 9. COMPONENT LIST

Resistors (All resistors will have a fourth band, which may be either gold or silver)

### (A)

Component No.	Value	Markings	Comments
R1	1K	Brown Black Red	
R2	470 Ohms	Yellow Purple Brown	
R3	1K	Brown Black Red	
R4	1K	Brown Black Red	
R5	1K	Brown Black Red	
R6	1K	Brown Black Red	
R7	1K	Brown Black Red	
R8	1K	Brown Black Red	
R9	1K	Brown Black Red	
R10	1K	Brown Black Red	
R11	1K	Brown Black Red	
R12	1K	Brown Black Red	
R13	47K	Yellow Purple Orange	
R14	47K	Yellow Purple Orange	
R15	47K	Yellow Purple Orange	
R16	47K	Yellow Purple Orange	
R17	47K	Yellow Purple Orange	
R18	1K	Brown Black Red	
R19	2K2	Red Red Red	
R20	330 Ohms	Orange Orange Brown	
R21	220K	Red Red Yellow	
R22	1K	Brown Black Red	
R23	1K	Brown Black Red	
R24	1K	Brown Black Red	
R25	470 Ohms	Yellow Purple Brown	
R26			Not used

R27	1K	Brown Black Red	
R28	47K	Yellow Purple Orange	
R29	180 Ohms	Brown Grey Brown	
R30	1K	Brown Black Red	
R31			Not used
R32	330 Ohms	Orange Orange Brown	
R33			Not used
R34	1K	Brown Black Red	
R35	1M	Brown Black Green	
R36			Not used
R37			Not used

### (B) Capacitors

Component No.	Value	Markings	Comments
C1	47n	473M, 473Z	
C2	47n	473M, 473Z	
C3			Not used
C4	47n	473M, 473Z	
C5	47n	473M, 473Z	
C6	47n	473M, 473Z	
C7			Not used
C8	22 $\mu$	22 $\mu$ 16v	
C9	47p	47, 47p, 470J	
C10	1 $\mu$	1 $\mu$ 63v	
C11	47p	47, 47p, 470J	
C12	100n	104, 0.1	
C13	47n	473M	
C14	47p	47, 47p, 470J	
C15	220p	220, 220p, 221 n22	33p for USA (60 Hz).

### (C) Semiconductors

Component No.	No. of pins	Type No.	Comments
IC1	40	D780C-1	
IC2	24	8332	OR TMS 4732, may be alternatively labelled.
IC3	18	$\mu$ PD2114LC*	
IC4	18	$\mu$ PD2114LC - 1	
IC5	20	74LS373	May be prefixed SN, DM, etc.
IC6	16	74LS157	"
IC7	16	74LS157	"
IC8	16	74LS157	"
IC9	16	74LS165	"
IC10	16	74LS367	or 74LS365
IC11	14	74LS00	
IC12	14	74LS00	

\*In case of supply difficulty may be same type as IC4.

IC13	14	74LS04	"
IC14	14	74LS05	"
IC15	14	74LS05	"
IC16	14	74LS10	"
IC17	14	74LS32	"
IC18	14	74LS74	"
IC19	14	74LS74	"
IC20	14	74LS86	"
IC21	14	74LS93	"
IC22	3	7805 or LM340T5	"
TRI			Not used
D3-D10		BA220 or BA221 or IN4448	D1 & D2 are not used. May be marked Red, Red, Black or Red, Red, Brown, Yellow, Yellow, Yellow, Grey.
D11		BA220 or IN4148	Only supplied for use on 525 line system to increase picture rate from 50 to 60 Hz.
X1		CDA6.5MC	3-lead ceramic filter

## 10. MISCELLANEOUS PARTS

3 off 3.5mm jack sockets

(NB — holes are provided for mounting 2 different styles of socket)

Modulator

Printed circuit board with keyboard

Regulator heatsink (Aluminium)

4BA nut, bolt and washer

Heatsink insulator (card)

Modulator insulator (card)

3 "W" buttons

Case upper moulding

2 black plastic rivets (to hold keyboard/pcb to lower moulding)

5 white plastic rivets (to hold upper and lower moulding together)

2 self adhesive foam strips (for feet)

Case lower moulding

IC sockets:-

11 x 14 pin

5 x 16 pin

2 x 18 pin

1 x 20 pin

1 x 24 pin

1 x 40 pin

## 11. SERVICE

If, after having built your ZX80, it fails to work we will service it for a flat rate service fee of £10. In the exceptional case where several of the IC's have been damaged we may request an additional payment. The service fee should be enclosed together with the faulty ZX80, as service will not be undertaken until the fee is received.

**IF THE FAULT WAS CAUSED BY FAULTY COMPONENTS SUPPLIED, WE WILL RETURN THE FULL SERVICE FEE.**

Under no account will we reassemble or complete the assembly of a ZX80 kit.

The address of the Service Department is:-

ZX80 Service Department, Science of Cambridge Ltd.,  
6 King's Parade, Cambridge CB2 1SN